

Loft in Primary Bedroom
 could be a den/reading nook/
 meditation space.

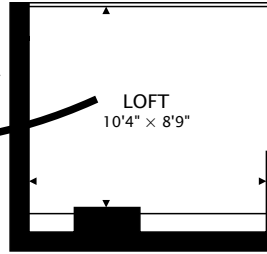

Den overlooking kitchen
 could be 2nd bedroom/
 home office/den/
 dining room.

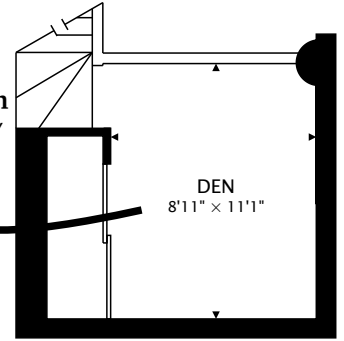

SECOND
 275 sq ft

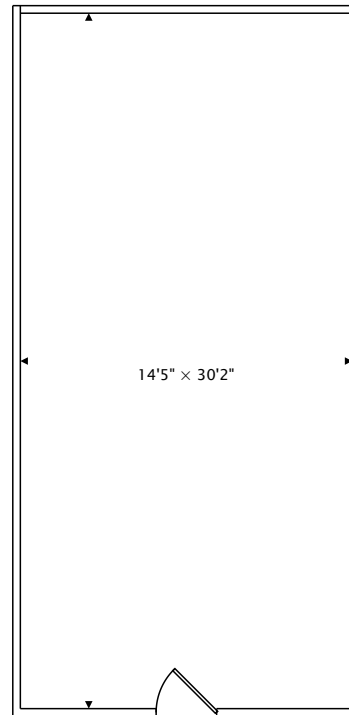

TERRACE
 435 sq ft TERRACE

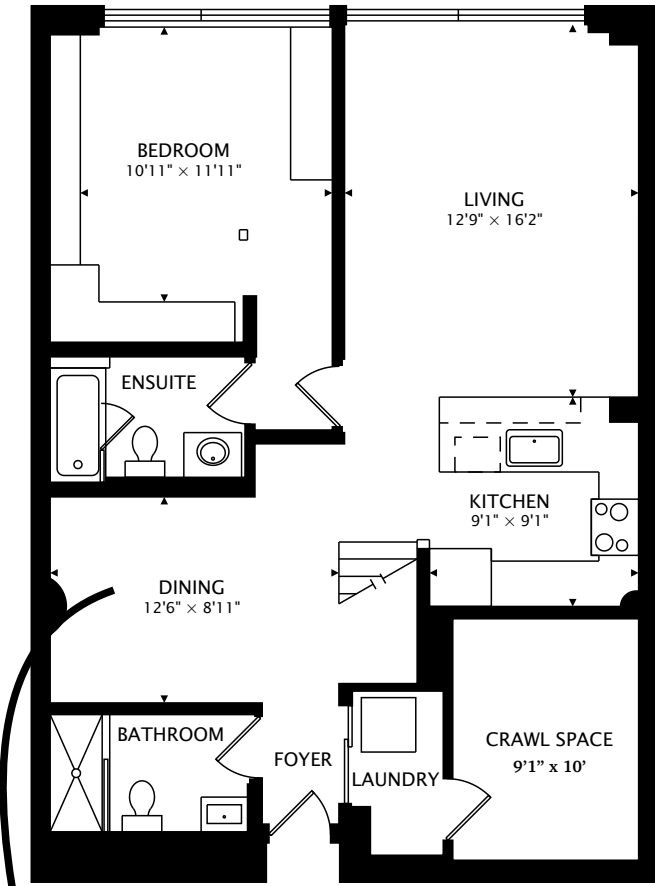

Dining room could be
 3rd bedroom/den/
 home office.

MAIN
 902 sq ft

TOTAL
 1177 sq ft + 435 sq ft TERRACE